

Runway Data									
Runway Identification	Existing		Future		Existing		Future		Runway 17/35
	Runway 8/26				Runway 17/35				
Runway Design Code (RDC)	B-II		B-II		B-II		B-II		B-II
Approach Reference Code (APRC)	B/III/5000 & D/II/5000		B/III/5000 & D/II/5000		B/III/5000		B/III/5000 & D/II/5000		B/III/5000 & D/II/5000
Departure Reference Code (DPRC)	B/III & D/II		B/III & D/II		B/III & D/II		B/III & D/II		B/III & D/II
Pavement Strength & Material Type	Bituminous Asphalt		Bituminous Asphalt		Bituminous Asphalt		Bituminous Asphalt		Bituminous Asphalt
Pavement Strength (x 1,000 LBS Wheel Loading.)	Single Wheel 30.0 / Dual Wheel 40.0		Single Wheel 30.0 / Dual Wheel 40.0		Single Wheel 30.0 / Dual Wheel 40.0		Single Wheel 30.0 / Dual Wheel 40.0		Single Wheel 30.0 / Dual Wheel 40.0
Pavement Strength (PCN)	9/F/B/Y/U		9/F/B/Y/U		9/F/B/Y/U		9/F/B/Y/U		9/F/B/Y/U
Pavement Strength Surface Treatment	None		None		None		None		None
Effective Runway Gradient (%)	0.32%		0.32%		0.13%		0.13%		0.13%
Percent (%) Wind Coverage	Refer to Wind Coverage Table		Refer to Wind Coverage Table		Refer to Wind Coverage Table		Refer to Wind Coverage Table		Refer to Wind Coverage Table
Runway Dimensions (L x W)	4,004' X 75'		5,004' X 75'		3,704' X 100'		3,704' X 75'		3,704' X 75'
Displaced Threshold	None		None		None		None		None
Runway Safety Area Dimensions	300' X 150'		300' X 150'		300' X 150'		300' X 150'		300' X 150'
Runway End Coordinates	Latitude:	N 29° 18' 03.14"	N 29° 18' 10.57"	N 29° 18' 01.29"	N 29° 18' 10.57"	N 29° 18' 19.14"	N 29° 17' 43.12"	N 29° 18' 19.14"	N 29° 17' 43.12"
	Longitude:	W 081° 07' 12.84"	W 081° 06' 28.42"	W 81° 07' 07.94"	W 081° 06' 28.42"	W 81° 06' 52.56"	W 81° 06' 44.73"	W 81° 06' 52.56"	W 81° 06' 44.73"
	Elevation:	27.5	20.6	27.5	20.6	25.2	25.9	25.2	25.9
Runway Lighting Type	MIRL		MIRL		MIRL		MIRL		MIRL
Runway Protection Zone (RPZ) Dimensions	1,000 x 500 x 700 feet		1,000 x 500 x 700 feet		1,000 x 500 x 700 feet		1,000 x 500 x 700 feet		1,000 x 500 x 700 feet
Runway Marking Type	Non-Precision		Non-Precision		Non-Precision		Non-Precision		Non-Precision
14 CFR Part 77 Approach Category	34:1		34:1		34:1		20:1		34:1
Approach Type	Non-Precision		Non-Precision		Non-Precision		Visual		Non-Precision
Visibility Minimums	5,000 RVR feet		5,000 RVR feet		5,000 RVR feet		N/A		5,000 RVR feet
Type of Aeronautical Survey Required for Approach	Non-Vertically Guided		Non-Vertically Guided		Non-Vertically Guided		Non-Vertically Guided		Non-Vertically Guided
Runway Departure Surface	Yes		Yes		Yes		N/A		N/A
Runway Object Free Area	300' X 500'		300' X 500'		300' X 500'		300' X 500'		300' X 500'
Obstacle Free Zone	200' X 400'		200' X 400'		200' X 400'		200' X 400'		200' X 400'
Threshold Siting Surface (TSS)	Table 3-2 Type 4		Table 3-2 Type 4		Table 3-2 Type 4		Table 3-2 Type 3		Table 3-2 Type 3
Visual and Instrument NAVAIDS	GPS/REIL/PAPI-2		GPS/REIL/PAPI-2		GPS/REIL/PAPI-4		REIL/PAPI-2		GPS/REIL/PAPI-4
Touch Down Zone Elevation	27.9		24.8		27.5		24.8		27.0
Taxiway Width	35'		25'		35'		35'		35'
Taxiway and Taxilane Safety Area Dimensions	79'		79'		79'		79'		79'
Taxiway and Taxilane Object Free Area	131'x115'		131'x115'		131'x115'		131'x115'		131'x115'
Taxiway and Taxilane Separation	300'		300'		200'		300'		300'
Taxiway / Taxilane Lighting	MITL		MITL		MITL		MITL		MITL
Horizontal and Vertical Datum	Horizontal	NAD 83 / NAD 88	NAD 83 / NAD 88	NAD 83 / NAD 88	NAD 83 / NAD 88	NAD 83 / NAD 88	NAD 83 / NAD 88	NAD 83 / NAD 88	NAD 83 / NAD 88
	Vertical	NAD 83	NAD 83	NAD 83	NAD 83	NAD 83	NAD 83	NAD 83	NAD 83

Airport Control				
Type	Description	Latitude	Longitude	Elevation
PAC	ORMONDPOR	N29° 18' 08.09232"	W81° 06' 53.11439"	24.9
SAC	ORMAIR AZ MK	N29° 18' 15.30271"	W81° 06' 40.10682"	21.8
SAC	ORMONDPOR AZ MK	N29° 18' 05.18236"	W81° 07' 13.28376"	25.7

SURVEY DATUM HORIZONTAL: NAD83 2011 (FLORIDA EAST) VERTICAL: NAVD 88, UNITS: SURVEY FOOT.
POINT INFORMATION BY: NGS/NOAA

AIRPORT DATA TABLE		
Item	Existing	Future
Airport Reference Code (ARC)	B-II	B-II
Mean Max Temperature of Hottest Month	90.2° Fahrenheit / July	
Airport Elevation (MSL)	27.9 feet	
Airport Electronic NAVAIDS	VORTAC	
Airport Reference Point (NAD 83)		
Latitude	N 29° 18' 04.1029"	N 29° 18' 03.8860"
Longitude	W 081° 06' 49.6752"	W 081° 06' 52.9728"
Miscellaneous Facilities	AWOS/Windcone w/ Segmented circle/MIRL/REIL/PAPI-2/MITL	AWOS/Windcone & Segmented circle/supplemental wind cone/MIRL/REIL/PAPI-4/MITL
Critical Aircraft	Cessna C525, C550, C560	Cessna C525, C550, C560
Wingspan	Group II	Group II
Approach Speed	Group B	Group B
Undercarriage	TDG 1B	TDG 1B
Magnetic Variation - 11/18/2014	08° 24' W	0° 02' W per year
NPIAS Service Level	GA-RL to DAB	
State Service Level / Asset Category	General Aviation	

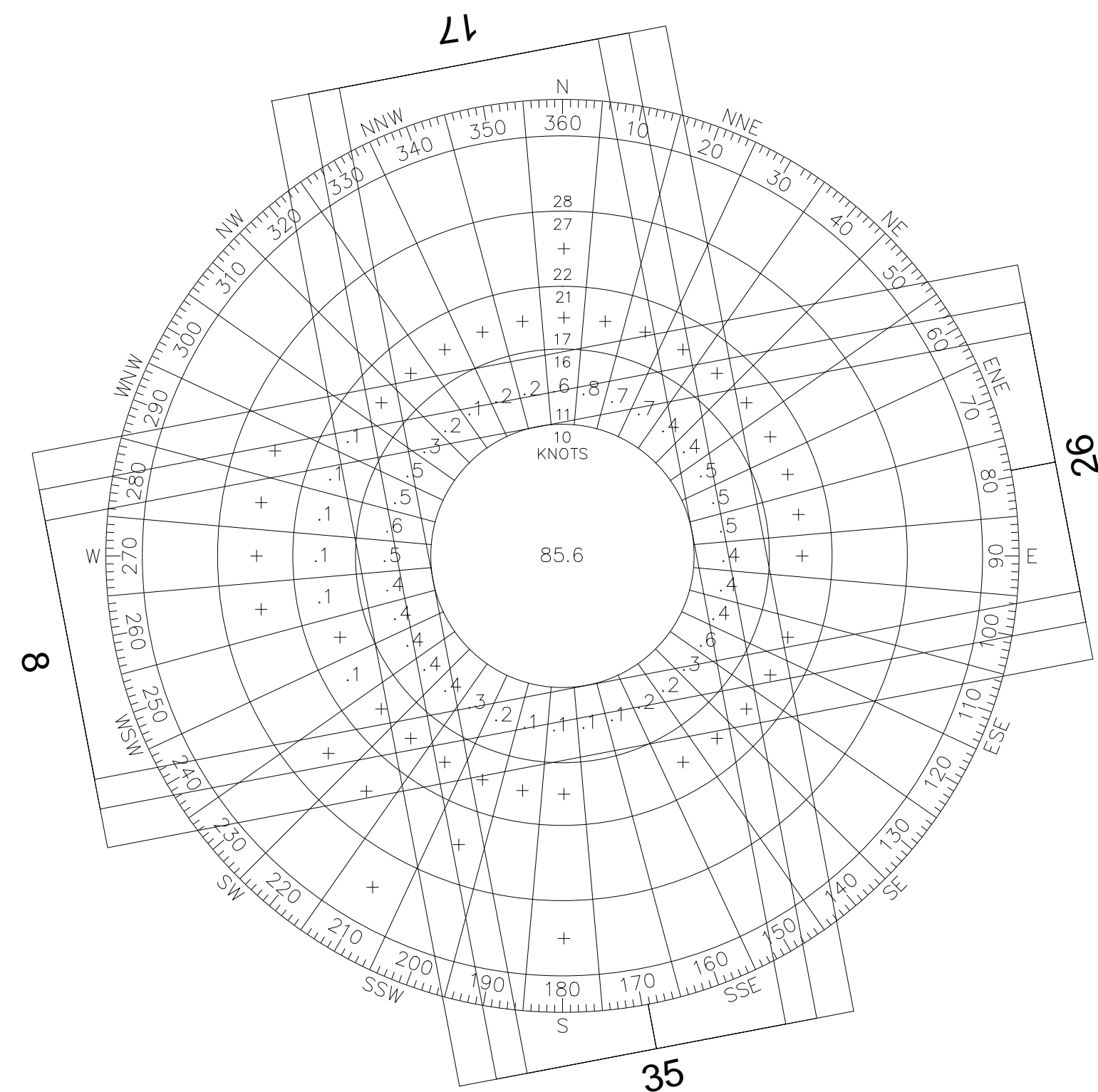

ALL WEATHER

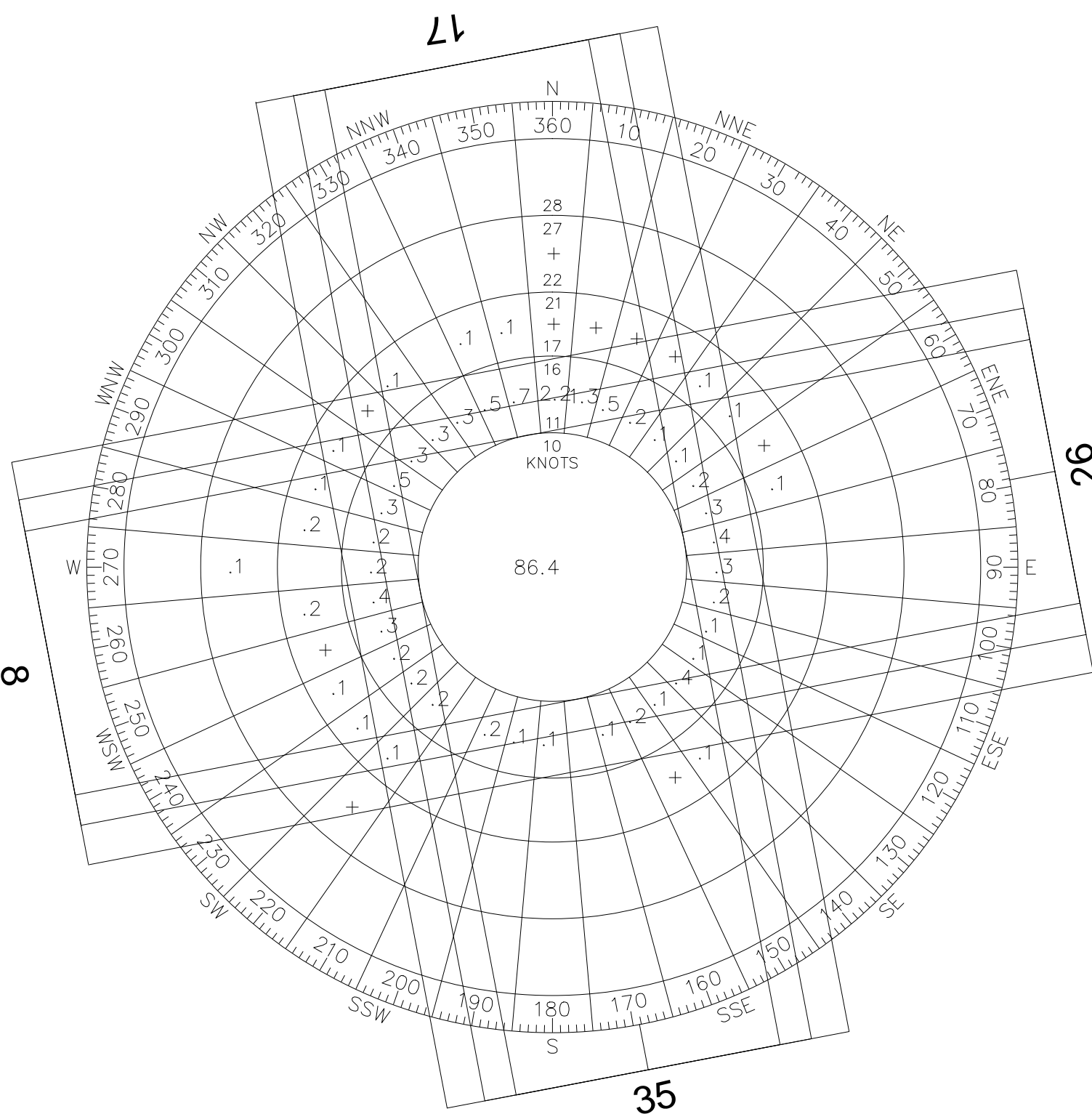

IFR WEATHER

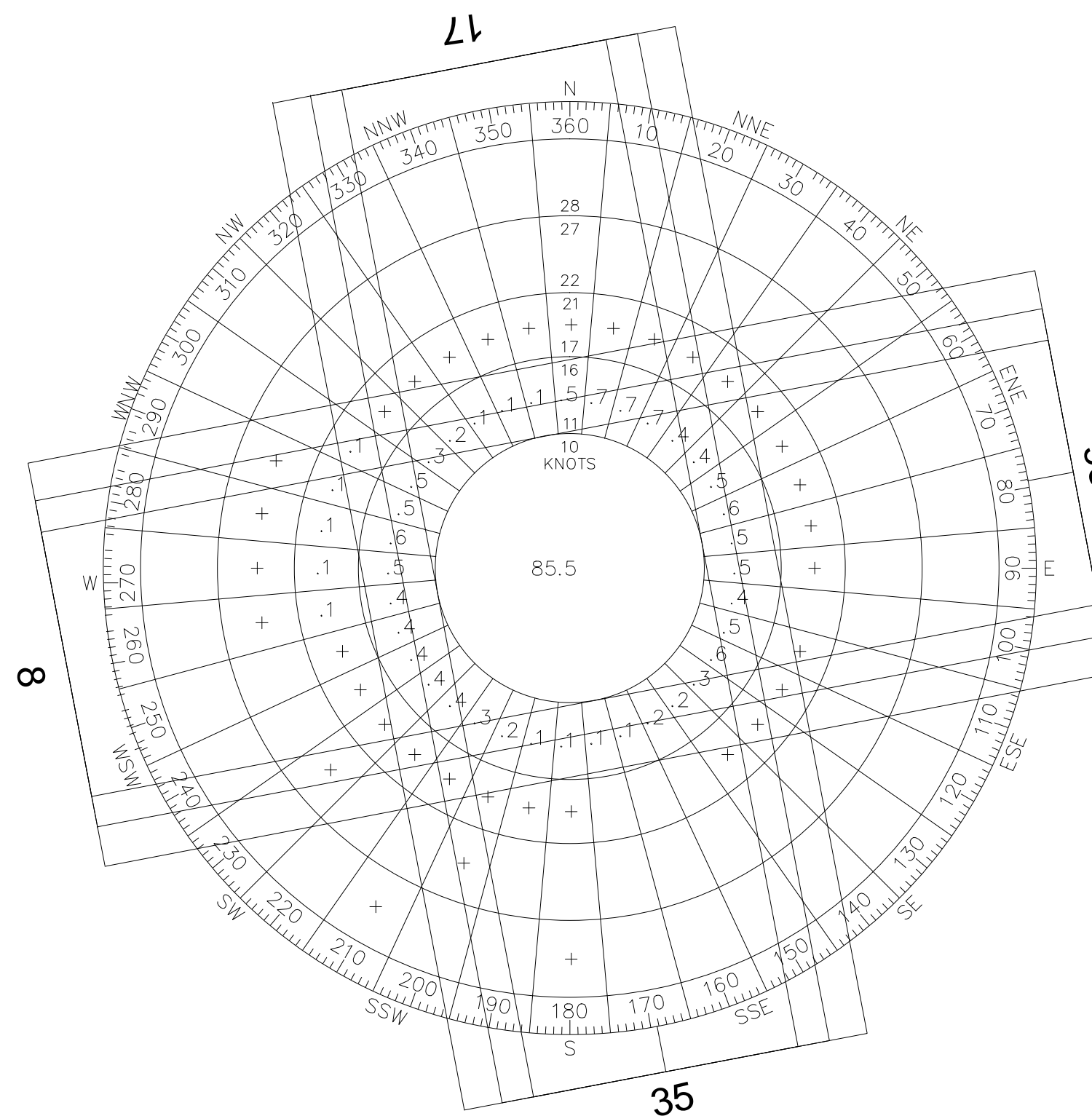

VFR WEATHER

Meteorological Condition	Observations	Runway	Wind Coverage Crosswind		
			10.5	13	16
All-Weather	36,836	8/26	95.40%	98.00%	99.72%
		17/35	92.30%	96.11%	99.28%
		Combined	99.40%	99.92%	99.98%
Visual Meteorological Conditions (VMC)	34,447	8/26	95.61%	98.15%	99.75%
		17/35	92.12%	96.05%	99.31%
		Combined	99.41%	99.93%	99.99%
Instrument Meteorological Conditions (IMC)	2,389	8/26	92.31%	95.76%	99.23%
		17/35	95.00%	96.93%	98.86%
		Combined	99.31%	99.82%	99.95%

Source: NDC: Station Ormond Beach Municipal (722341), year 2004 to 2015. (Years 2004 and 2015 partial data)
Percentages generated with the FAA Wind Analysis Tool: <https://airports-gis.faa.gov>

DECLARED DISTANCES				
Runway	TORA	TODA	ASDA	LDA
8	4,004	4,004	4,004	4,004
26	4,004	4,004	4,004	4,004
17	3,704	3,704	3,704	3,704
35	3,704	3,704	3,704	3,704

Modification to Standards Approval			
Approval Date	Airspace Case No.	Standard to be Modified	Description
			None Required

3-12-0059-17-2014	AIP NO.:	307101
	PROJ. NO.:	JLC
	DRAWN:	MTO
	DESIGN:	ERMI
	CHECKED:	OCTOBER 2015
	DATE:	

REV. NO.	DATE	DESCRIPTION

SHEET TITLE
DATA SHEET

CITY OF ORMOND BEACH
ORMOND BEACH MUNICIPAL AIRPORT
ORMOND BEACH, FLORIDA



Hoyle Tanner
& Associates, Inc.

95 E. Mitchell, Hammock Road,
Suite 200 Oviedo, FL 32765
Office PH: 407-380-1919
Fax: 407-380-1830
www.hoyletanner.com